

Mark Plate, Switch and Rail designation on both ends.  
(See Note No.4)

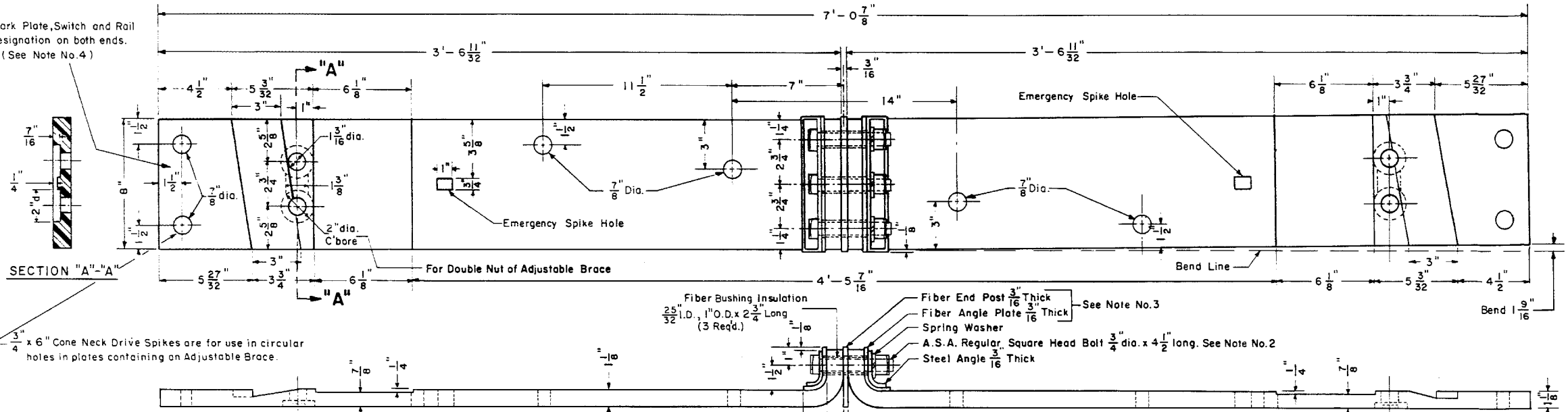

**NO. 1-G INSULATED GAGE PLATE**

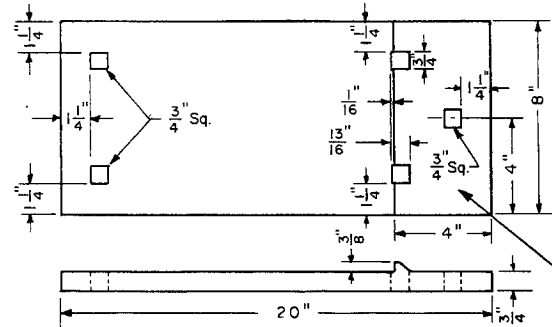

**NO. 3 SHOULDER SLIDE PLATE**

Mark Plate, Switch and Rail designations here.  
(See Note No.4)

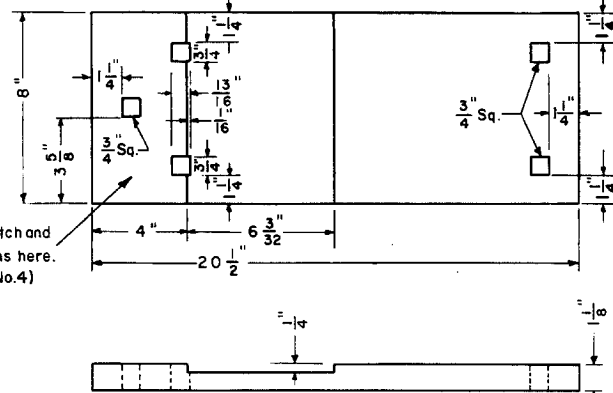

**NO. 1-P SHOULDER SLIDE PLATE**

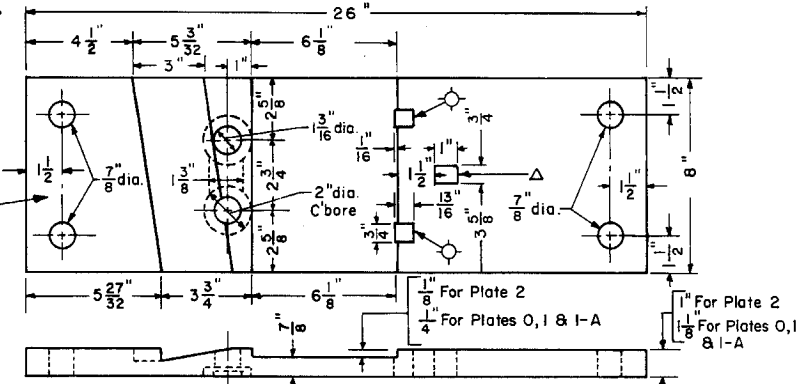

**NO. 0, NO. 1, NO. 1-A & NO. 2  
ADJUSTABLE BRACE SLIDE PLATES**

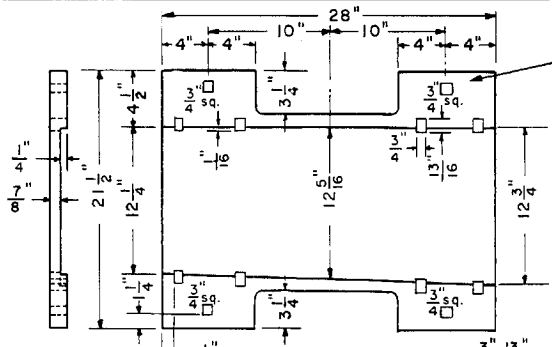

**NO. SH (R.H. & L.H.) HEEL PLATES**

**NOTES**

- 1 - Switch Plates shall conform to current A.R.E.A. Specifications for Low-Carbon Steel Tie Plates, with copper.
- 2 - All gage plate bolts shall have A.S.A. Regular square heads and A.S.A. Heavy square nuts. All bolts shall be carbon-steel with medium-carbon steel nuts and conform to current A.R.E.A. "Specifications for Heat-Treated Carbon-Steel Track Bolts and Carbon Steel Nuts."
- 3 - All fiber parts shall conform to current A.A.R. Signal Section Manual, Part 58, Specification No. 13 for "Hard Fiber" and A.A.R. Signal Section Manual, Part No. 178 covering "Requisites for Fabricated Fiber Parts for Track Insulation."
- 4 - Each plate shall be marked by deeply cut characters, not less than one half inch high, in the position as indicated on this plan, with the plate, switch and rail designations. Example I-P, 16-6, J32



STANDARD  
**SWITCH PLATES and GAGE PLATE**  
FOR 16'-6" SWITCH-132 LB RAIL

*R.H. Smith*  
Chief Engineer - Maintenance of Way

NOVEMBER 1976

*R.A. Gardner*  
Chief Engineering Officer