

Rev. A-10-25-84: top of ground rod was 6" to 12" below top of ground. Added item 4. Wire from prime ground grid to ground was insulated. Added items 5 thru 9.

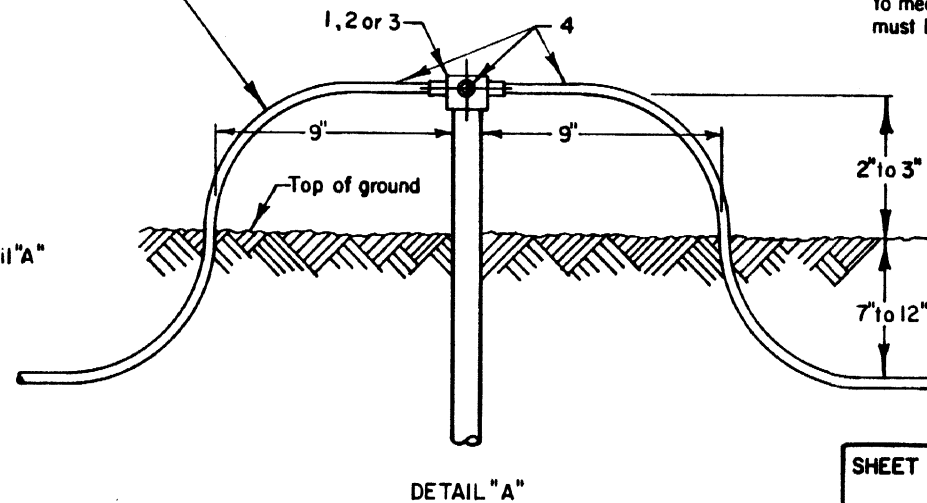
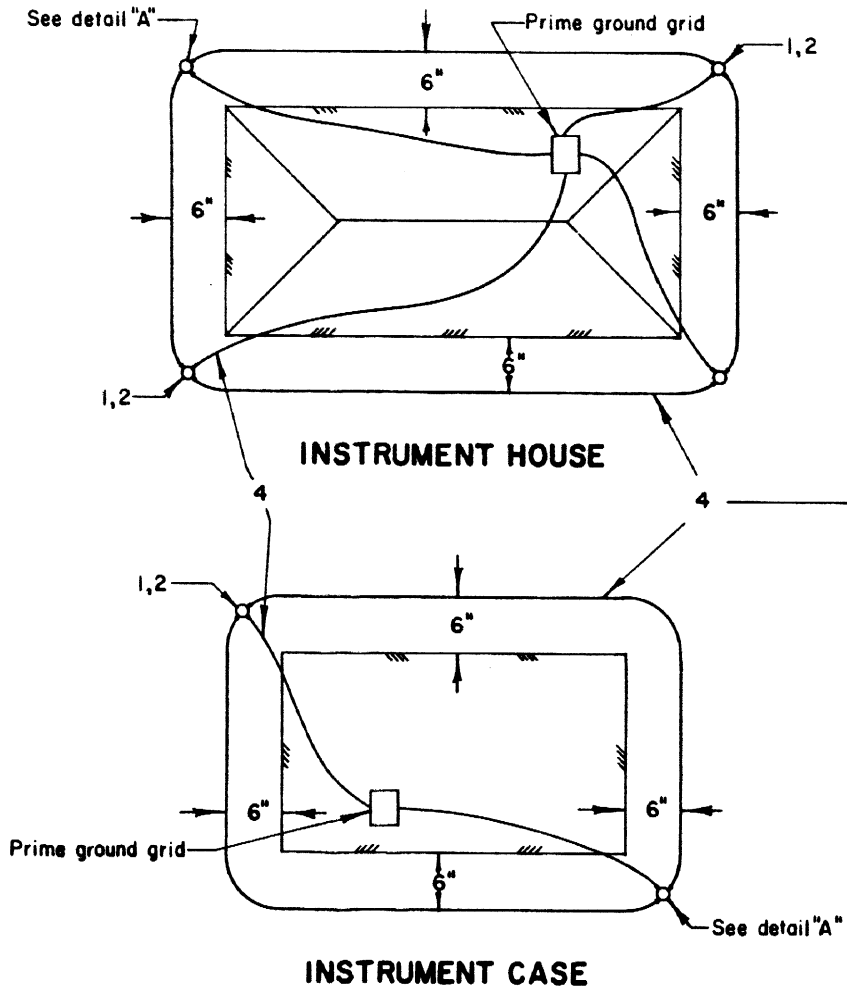

NO	ITEM	PART NO.	ACCT. REF NO.
1	Connection, exo. weld, 3 wire	SBNTI-161G	02-742243
2	Rod, copperweld ground, 2 Dia x 8 lg	SB858	02-829263
3	Rod, copperweld ground, threaded		02-829313
4	Wire, No. 6 AWG solid, bare, soft		49-779709
5	Mold, ground rod exo. weld	PBIOGB-16	
6	Stud, drive for 5/8 ground rod	BI37-16	02-563664
7	Connection, exo. weld, 2 wire	SBGTI-161G	02-742227
8	Connection, exo. weld, 1 wire	SBGRI-161G	02-742151
9	Coupling, ground rod thread		02-165106

NOTES:

1. Make ground wires as short as possible.
2. Avoid sharp bends in ground wires. Radius of bends must be more than 6 inches.
3. Resistance between prime ground grid and earth not to exceed 5 ohms.
4. Ground rod & cable connecting surfaces must be thoroughly cleaned (to bright metal) by sanding or grinding before applying exothermic weld.
5. Use drive stud when installing ground rods. Item No. 6
6. Use No. 6 AWG solid, bare, soft copper wire to connect prime ground grid to ground rods. See item No. 4.
7. When 2 or more ground rods must be connected end to end to meet 5 ohm resistance requirement, exothermic welds must be used between rods and couplings. Item No. 5

SHEET 1



CS-9002-A

STANDARD
INSTRUMENT HOUSE & CASE
GROUNDING APPLICATION

AUG. 2, 1982

Approved *H. A. Brindley*
Chief Engineer CBS

Rev. Oct. 13, 1986